

**Aruncator inclinat,
UniLifter®**

INFO

S6370/ ... (CBMM ...), S6371/ ... (CBS ...)

Aruncator inclinat, Forma patrata

S6372/ ... (CBMM ...), S6373/ ... (CBS ...)

Aruncator inclinat, Forma rotunda

S6374/ ... (UCMM ...), S6375/ ... (UC ...)

Racord tip U pentru aruncator inclinat

S6376/ ... (TGMM ...), S6377/ ... (TG ...)

Bara de ghidare tip T pentru aruncator inclinat

**Core blade,
UniLifter®**

INFO

Slanted Ejector, Square Design

Slanted Ejector, Round Design

U-Coupling, for Slanted Ejector

T-Guide Bar, for Slanted Ejector

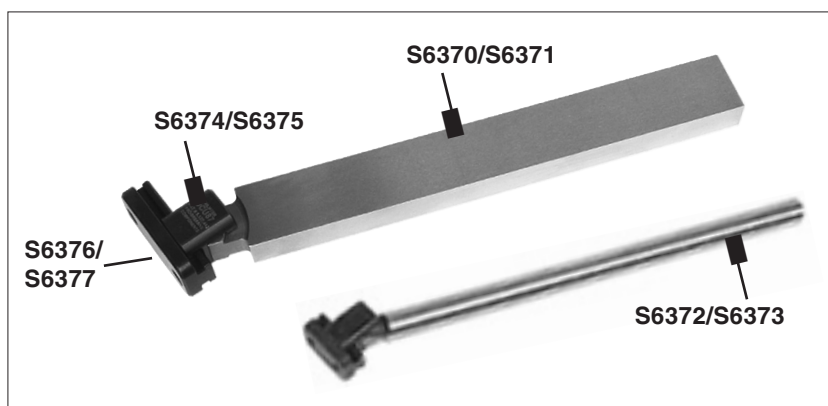
**Inclus in pachet:**

1. Aruncator inclinat
2. Racord tip U
3. Bara de ghidare tip T

Va rugam comandați fiecare componenta separat!

Delivery includes:

1. Core blade
2. U-coupling
3. T-guide bar

Please order each component separately!

Cereri pentru aplicatie:

1. Unghiul specific este de 5-10°, desi utilizatorii au instalat cu succes si cu unghiuri mai mari. Contactati departamentul tehnic pentru analiza aplicatiei.
2. Este recomandata folosirea aruncatoarelor cu ghidaj, si daca este mai putin de jumătate a aruncatorului inclinat in insertie, trebuie adaugata o placa de ghidaj suplimentar.
3. Jocul recomandat este de 0,025 pana 0,038 mm, unde este permis.
4. Verificati daca materialul insertiei miezului este de cel puțin 10 HRc, diferit fata de aruncatoarele inclinate standard, si pentru performante suplimentare, se pot aplica straturi si tratamente pentru o duritate mai mare si lubrifiere mai buna.
5. Unghiurile de inchidere pot fi proiectate pentru a suporta presiunea de injectie si dimensiuni non-standard sau aruncatoare inclinate subtiata pot fi deasemenea furnizate.

Application Guidelines:

1. Typical angle is 5-10°, though users report success at greater angles with guides installed. Contact engineering department for application review.
2. Guided ejection is recommended, and if there is less than half of the core blade bearing in the insert, lifter guide plates should be added.
3. Recommended clearance is 0,025 – 0,038mm, where permissible.
4. Verify that the core insert material is at least 10 HRc different from standard core blades, and for additional performance, consider coatings or treatments for increased hardness or lubricity.
5. Locking angles can be designed to accept moulding pressure, and non-standard sizes or pre-roughed core blades can also be provided.

Aruncator inclinat, UniLifter®

INFO

S6370/ ... (CBMM ...), S6371/ ... (CBS ...)

Aruncator inclinat, Forma patrata

S6372/ ... (CBMM ...), S6373/ ... (CBS ...)

Aruncator inclinat, Forma rotunda

S6374/ ... (UCMM ...), S6375/ ... (UC ...)

Racord tip U pentru aruncator inclinat

S6376/ ... (TGMM ...), S6377/ ... (TG ...)

Bara de ghidare tip T pentru aruncator inclinat

Core Blades, UniLifter®

INFO

Slanted Ejector, Square Design

Slanted Ejector, Round Design

U-Coupling for Slanted Ejector

T-Guide Bar for Slanted Ejector

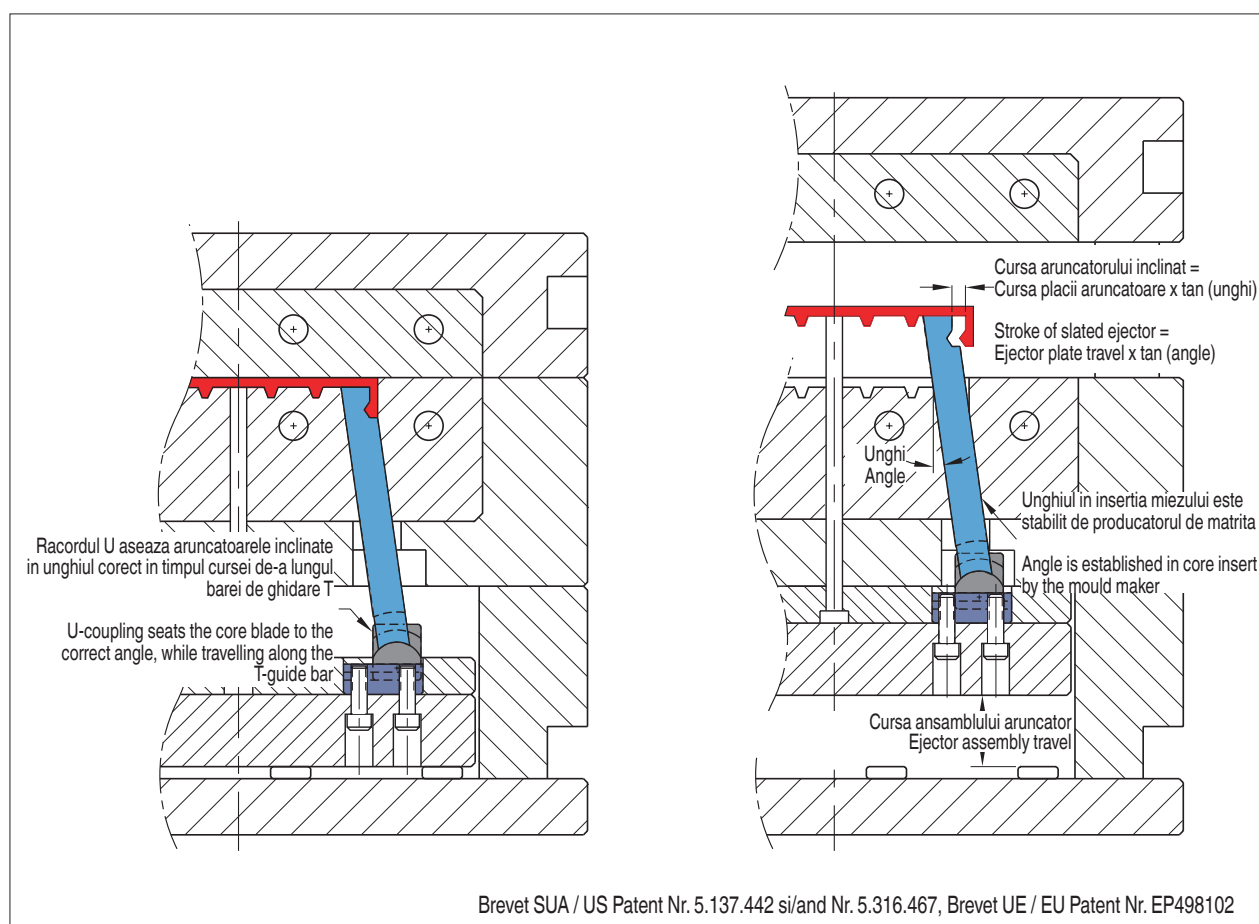

| Aruncator inclinat Slanted ejector | adekvat pentru racordul U suitable for U-coupling | adekvat pentru bara de ghidare T suitable for T-guide bar |
|---------------------------------------|--|--|
| S6370/ ... | S6374/ 22 | S6376/ ... |
| S6371/ ... (R = .250) | S6375/ 50 | S6377/ 50 ... |
| S6371/ ... (R = .406) | S6375/ 87 | S6377/ 87 ... |
| S6371/ ... (R = .875) | S6375/ 175 | S6377/ 175 ... |
| S6372/ ... | S6374/ 22 | S6376/ ... |
| S6373/ ... (R = .250) | S6375/ 50 | S6377/ 50 ... |
| S6373/ ... (R = .406) | S6375/ 87 | S6377/ 87 ... |
| S6373/ ... (R = .875) | S6375/ 175 | S6377/ 175 ... |

Aruncator inclinat,
Forma patrata

S6370/ ... (CBMM ...)

Dimensiuni metrice

Material: 1.2344
Duritate: 38 - 42 HRc

Produse personalizate sunt disponibile la cerere.

Slanted Ejector,
Square Design

Metric dimensions

Material: 1.2344
Hardness: 38 - 42 HRc

Custom-made products are available on request.

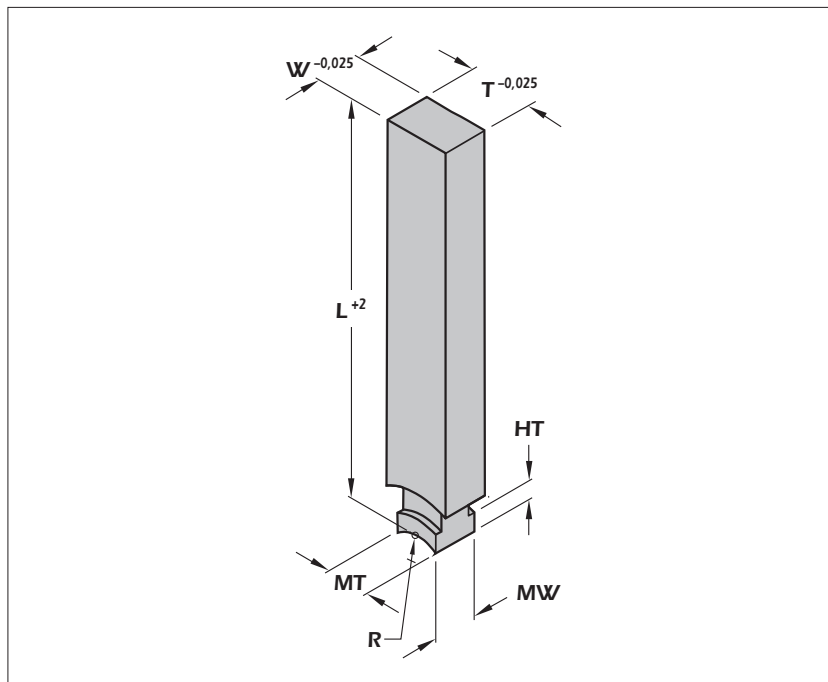

| MW | R | HT | T | W | L | MT min. | Nr. / No. |
|----|----|----|-------|-------|-----|------------|------------------|
| 10 | 10 | 5 | 10,25 | 10,25 | 250 | 10 | S6370/ 10x10x250 |
| | | | | 20,25 | | | 10x20x250 |
| | | | 15,25 | 15,25 | 400 | 15 | 15x15x250 |
| | | | | 30,25 | | | 15x30x400 |
| | | | 20,25 | 10,25 | 250 | | 20x10x250 |
| | | | | 20,25 | 400 | | 20x20x400 |
| | | | 30,25 | 15,25 | | | 30x15x400 |

Aruncator inclinat, Forma patrata

S6371/ ... (CBS ...)

Dimensiuni in toli

Material: 1.2344
Duritate: 38 - 42 HRc

Gama completa a MW = .500 este de asemenea disponibil din aluminiu-bronz.

Produse personalizate sunt disponibile la cerere.

Slanted Ejector, Square Design

Inch dimensions

Material: 1.2344
Hardness: 38 - 42 HRc

The complete range of MW = .500 is also available in aluminium bronze.

Custom-made products are available on request.

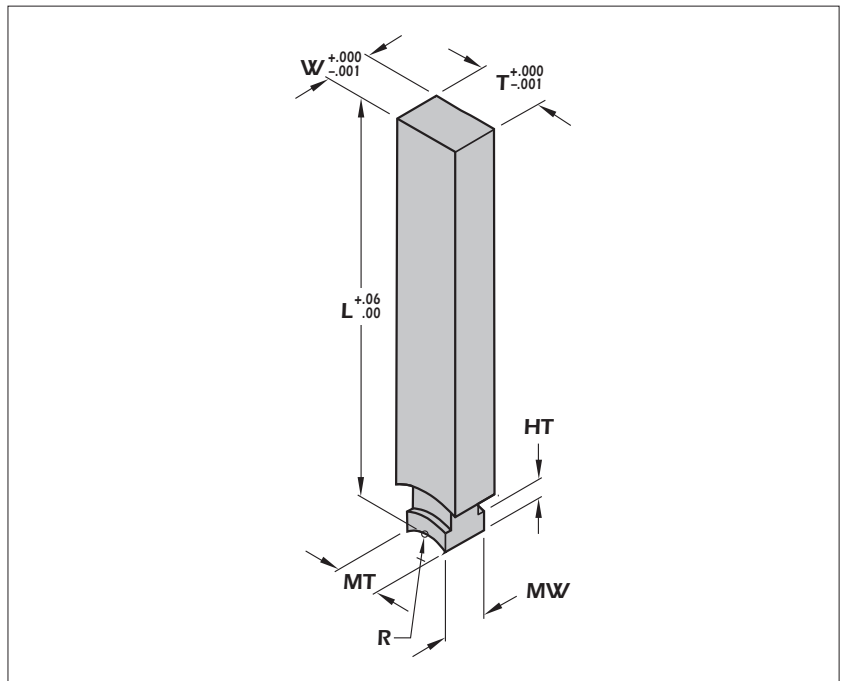

| MW | R | HT | T | W | L | MT min. | Nr. / No. | | | |
|-------|------|------|-------|-------|-------|------------|-------------------|------|------------|------------|
| .250 | .250 | .156 | .385 | .260 | 8 | .25 | S6371/ 37x25x8 | | | |
| | | | .510 | | | | 50x25x8 | | | |
| | | | .760 | | | | 75x37x8 | | | |
| .500 | .406 | .187 | .510 | .510 | 8 | .49 | S6371/ 50x50x8 | | | |
| | | | | | 14 | | 50x50x14 | | | |
| | | | | | 8 | | 50x100x8 | | | |
| | | | .760 | .510 | .510 | .510 | 14 | .62 | 50x100x14 | |
| | | | | | | | 8 | | 50x150x14 | |
| | | | | | | | 14 | | 75x50x14 | |
| | | | 1.010 | .510 | .510 | .510 | 8 | .62 | 75x150x8 | |
| | | | | | | | 14 | | 75x150x14 | |
| | | | | | | | 8 | | 100x50x8 | |
| | | | 1.510 | .510 | .510 | .510 | 14 | .62 | 100x50x14 | |
| | | | | | | | 8 | | 150x50x8 | |
| | | | | | | | 14 | | 150x50x14 | |
| | | | | | | | 8 | | 150x75x8 | |
| | | | | | | | 14 | | 150x75x14 | |
| | | | | | | | 8 | | 150x75x14 | |
| 1.000 | .875 | .375 | 1.010 | 1.010 | 10 | 1.00 | S6371/ 100x100x10 | | | |
| | | | | | 18 | | 100x100x18 | | | |
| | | | | | 10 | | 100x150x10 | | | |
| | | | 1.510 | 1.010 | 1.010 | | 18 | 1.00 | 100x150x18 | |
| | | | | | | | 10 | | 150x100x10 | |
| | | | | | | | 18 | | 150x100x18 | |
| | | | 1.510 | 1.010 | 1.010 | | 1.010 | 10 | 1.00 | 150x100x10 |
| | | | | | | | | 18 | | 150x100x18 |
| | | | | | | | | 18 | | 150x100x18 |

**Aruncator inclinat,
Forma rotunda****S6372/ ... (CBMM ...)****Dimensiuni metrice****S6373/ ... (CBS ...)****Dimensiuni in toli**

Material: 1.2344
Duritate: 38 - 42 HRc

Gama completa a MW = .500 este de asemenea disponibil din aluminiu-bronz.

Produce personalizate sunt disponibile la cerere.

**Slanted Ejector,
Round Design****Metric dimensions****Inch dimensions**

Material: 1.2344
Hardness: 38 - 42 HRc

The complete range of MW = .500 is also available in aluminium bronze.

Custom-made products are available on request.

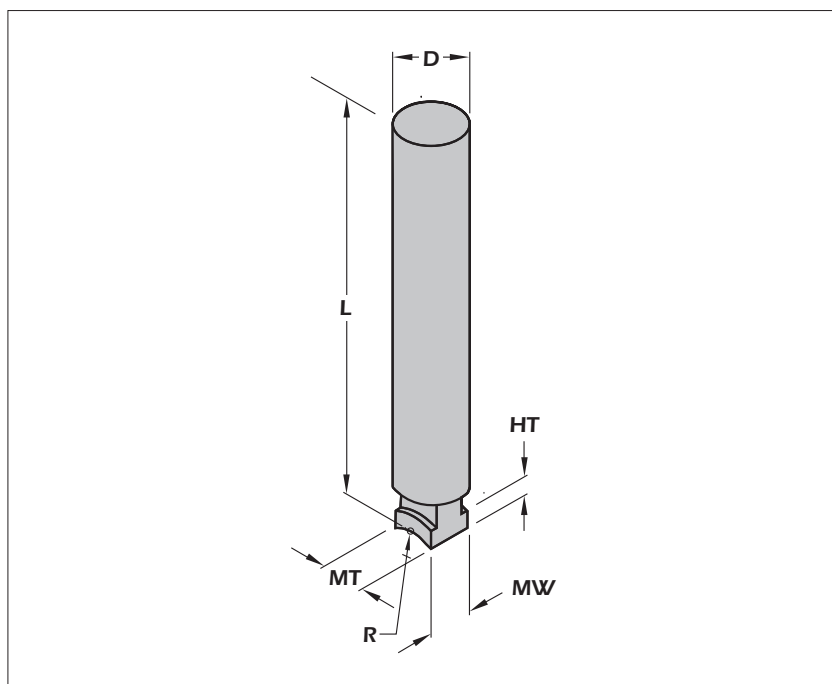

| MW | R | HT | D | L | MT | Nr. / No. |
|----|----|----|--------------|-----|----|---------------|
| 10 | 10 | 5 | -0.025 10 | 250 | 10 | S6372/ 10x250 |
| | | | 15 | | | 15x250 |

| MW | R | HT | D | L | MT | Nr. / No. |
|-------|------|------|--------------------------|-------------------|------|---------------|
| .250 | .250 | .156 | +0.000 -0.001 .437 | +0.06 .00 8 | .31 | S6373/ 43x8 |
| .500 | .406 | .187 | .750 | 8 | .62 | S6373/ 75x8 |
| | | | | 14 | | 75x14 |
| | | | | 18 | | 75x18 |
| 1.000 | .875 | .375 | 1.250 | 10 | 1.00 | S6373/ 125x10 |
| | | | | 18 | | 125x18 |

Racord tip U pentru aruncator inclinat

S6374/ ... (UCMM ...)

Dimensiuni metrice

S6375/ ... (UC ...)

Dimensiuni in toli

Material: 1.2344
Suprafata: brunat

U-Coupling, for Slanted Ejector

Metric dimensions

Inch dimensions

Material: 1.2344
Surface: Blackened

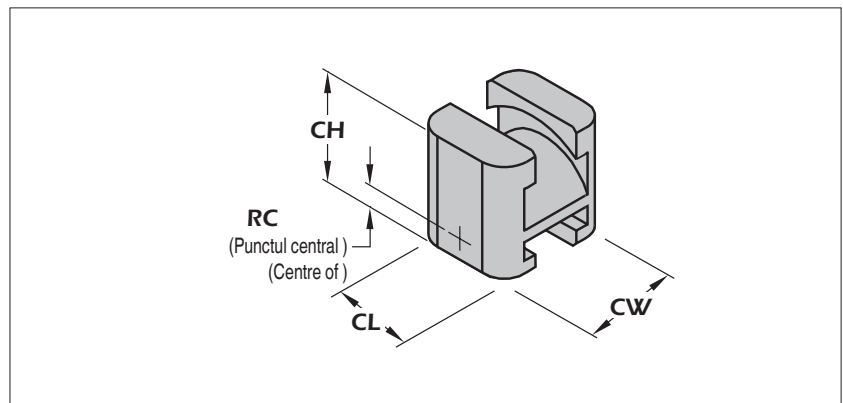

| R | RC | CW | CL | CH | Nr. / No. |
|----|----|----|----|----|-----------|
| 10 | 6 | 22 | 18 | 25 | S6374/ 22 |

| R | RC | CW | CL | CH | Nr. / No. |
|------|------|------|------|------|-----------|
| .250 | .125 | .50 | .44 | .62 | S6375/ 50 |
| .406 | .187 | .87 | .75 | .87 | 87 |
| .875 | .125 | 1.75 | 1.50 | 1.65 | 175 |

Bara de ghidare tip T

Pentru aruncator inclinat S6374/S6375

S6376/ ... (TGMM ...)

Dimensiuni metrice

S6377/ ... (TG ...)

Dimensiuni in toli

Material: 1.2344
Suprafata: brunat

Suruburi incluse in pachet

T-Guide Bar

For Slanted Ejector S6374/S6375

Metric dimensions

Inch dimensions

Material: 1.2344
Surface: Blackened

Screws are included in delivery.

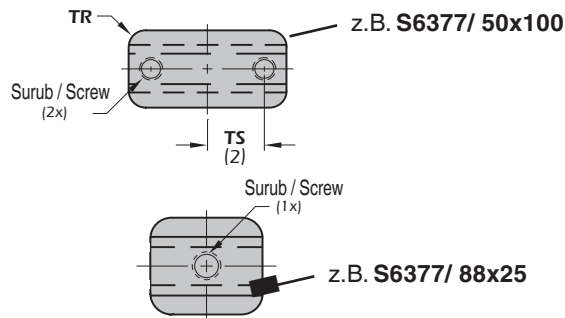
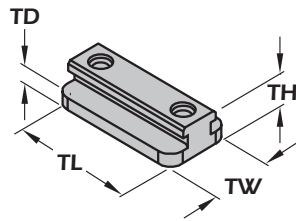

| TW -0,025 | TH +0,25 | TD +0,25 | TR | Surub Screw | TS | TL -0,25 | S max. | Nr. / No. |
|--------------|-------------|-------------|----|----------------|----|-------------|-----------|--------------|
| 22 | 13 | 6 | 5 | 2 x M5x20 | 10 | 33 | 10 | S6376/ 22x33 |
| | | | | | 15 | 52 | 30 | 52 |

| TW +.000 -.001 | TH +.010 .000 | TD +.010 .000 | TR | Surub Screw | TS | TL .000 -.010 | S max. | Nr. / No. |
|----------------------|---------------------|---------------------|------|------------------|-------|---------------------|-----------|----------------|
| .500 | .500 | .344 | .093 | 1 x #10-32x1 | - | .750 | .312 | S6377/ 50x75 |
| | | | | 2 x #10-32x1 | .500 | 1.500 | 1.000 | 150 |
| .875 | .468 | .219 | .187 | 1 x 1/4-20x3/4 | - | 1.000 | .250 | S6377/ 87x100 |
| | | | | 2 x 1/4-20x3/4 | .375 | 1.250 | .500 | 125 |
| | | | | | .625 | 1.750 | 1.000 | 175 |
| | | | | | .750 | 2.250 | 1.500 | 225 |
| 1.750 | .625 | .250 | .312 | 2 x 3/8-16x1-1/4 | .625 | 2.000 | .500 | S6377/ 175x200 |
| | | | | | .875 | 2.500 | 1.000 | 250 |
| | | | | | 1.375 | 4.000 | 2.500 | 400 |