

Elemente de racire cu fixare, spiralate

INFO

S3121/ ... (RLAS ... SM)

Instructiuni de instalare

1. Stabiliti locatia gaurii si fixati instrumentul de bro sare in masina de gaurit.
2. Centratii instrumentul de bro sare (ex. 6 mm) si introduceti in gaura.
3. Acum ajustati marginile de taiere a instrumentului de bro sare.
4. Apoi prin scaderea axului masinii de gaurit, introduceti cu atentie slotul de localizare (nu porniti masina de gaurit!).

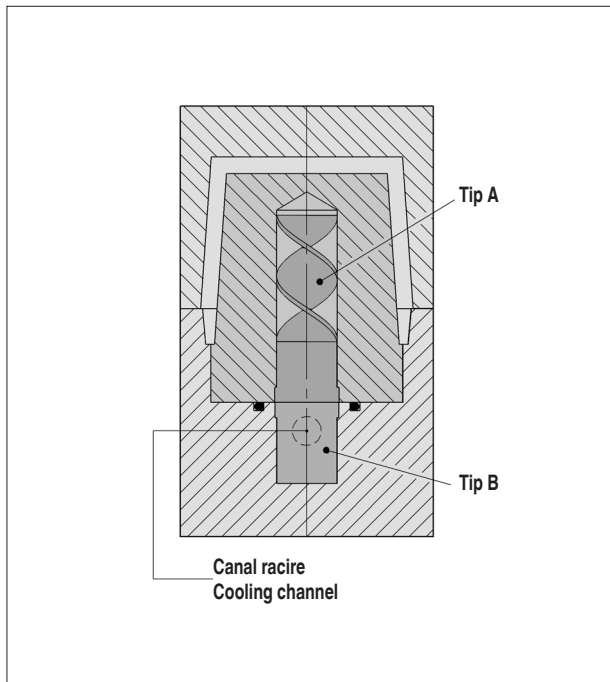

Spiral Auto-Locking Cooling Elements

INFO

Mounting instructions:

1. Establish location hole and clamp broaching tool into drilling machine.
2. Centring of broaching tool (i.e. 6 mm) insert into the borehole.
3. Now adjust cutting edges of the broaching tool.
4. Afterwards plunge the positioning-slots by lowering the spindle of the drilling machine (do not switch-on the drilling machine!).

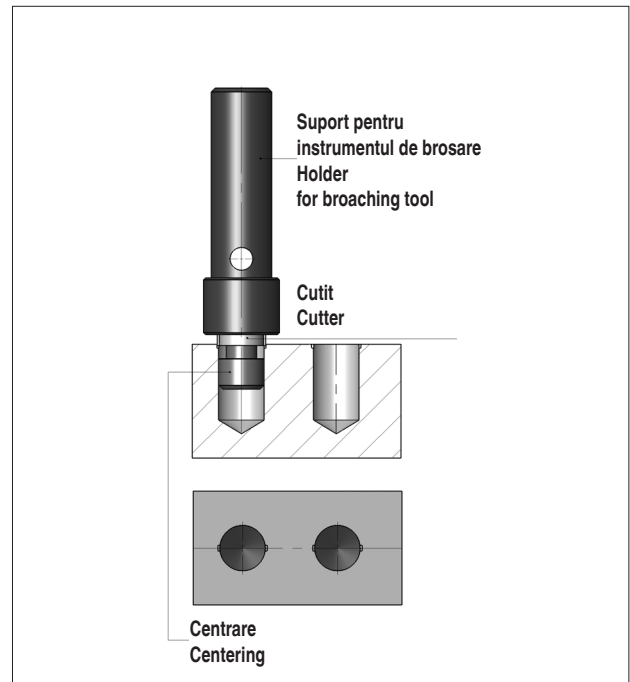

Elemente de racire
cu fixare, spiralate

Spiral Auto-Locking
Cooling Elements

S3121/ ... (RLAS ... SM)

Material: Otel inoxidabil

Material: Stainless steel

Pentru instrumente de brosare
vedeti pagina 7.24

For broaching tool
see page 7.24

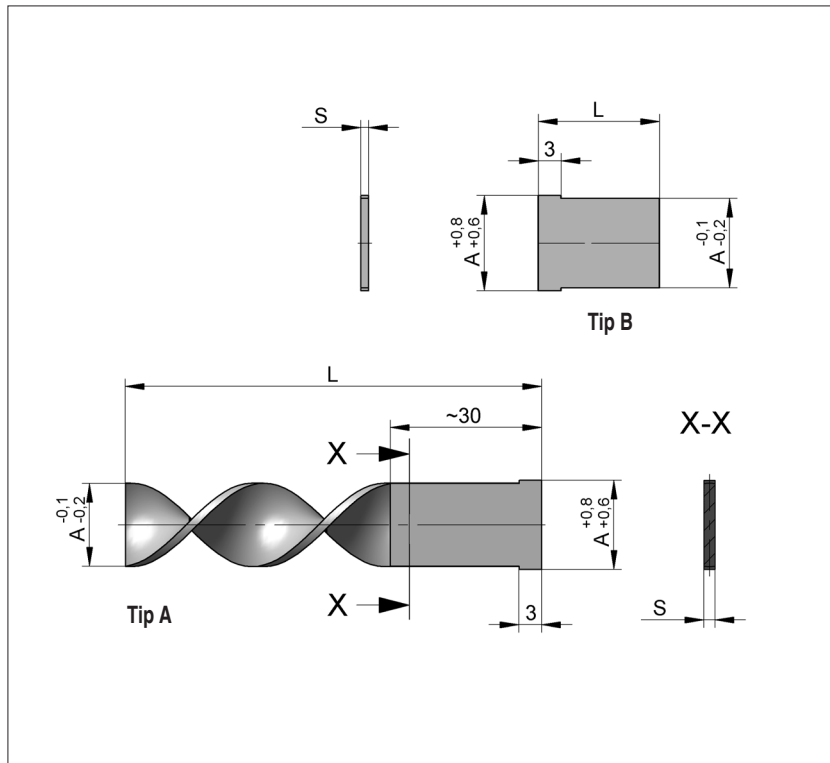

A	S	L (Tip A)	L (Tip 8)	Nr. / No.
6	1	-	14	S3121/ 6 x 14
		100	-	100
		200	-	200
8	1	-	16	S3121/ 8 x 16
		100	-	100
		200	-	200
10	1	-	18	S3121/ 10 x 18
		100	-	100
		200	-	200
12	1	-	20	S3121/ 12 x 20
		100	-	100
		200	-	200
14	1	-	22	S3121/ 14 x 22
		100	-	100
		200	-	200
16	1	-	24	S3121/ 16 x 24
		150	-	150
		300	-	300
20	1,5	-	26	S3121/ 20 x 26
		150	-	150
		300	-	300
25	1,5	-	28	S3121/ 25 x 28
		150	-	150
		300	-	300

Alte dimensiuni la cerere!

Other dimensions on request!