

Bara zavor

Latch Bar

S6205/ ... (ZH 90 ...)

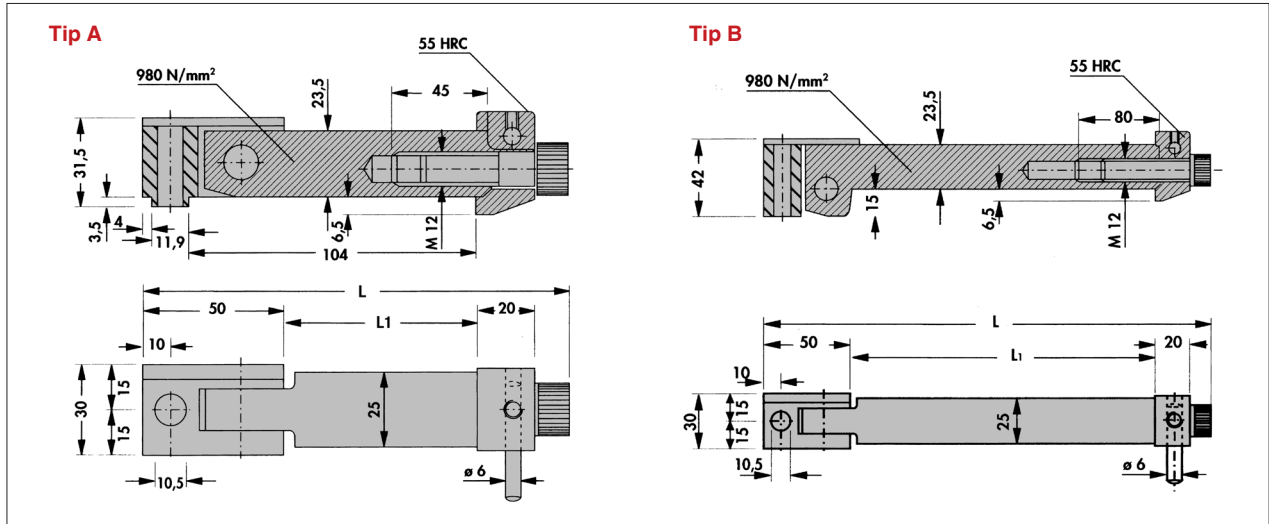

Tip	L	L1	F _{max} [daN]	Nr. / No.
A	152	70	4000	S6205/ 70
B	172	90	6000	90
	252	170	6000	170
	302	220	6000	220
	352	270	6000	270

Bara control

Control Bar

S6206/ ... (ZH 90/ 0 ...)

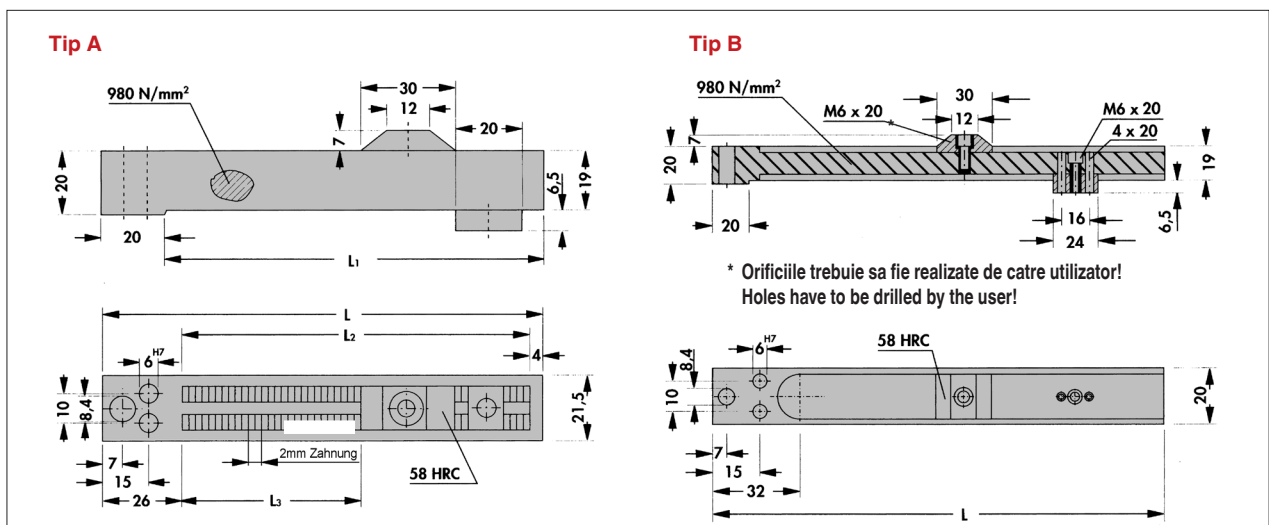

Tip	L	L1	L2	L3 _{max}	Nr. / No.
A	140	120	110	60	S6206/ A 140
B	200	-	-	-	B 200
A	204	184	174	124	A 204
B	250	-	-	-	B 250
A	250	230	220	220	A 250
B	300	-	-	-	B 300